

OPEN ACCESS

Design optimization of a centrifugal pump impeller and volute using computational fluid dynamics

To cite this article: J H Kim *et al* 2012 *IOP Conf. Ser.: Earth Environ. Sci.* **15** 032025

View the [article online](#) for updates and enhancements.

You may also like

- [Numerical study on hydraulic and self-priming performance of a double-stage self-priming pump](#)
H Y Yao, Y D Zhang, D Z Wu *et al.*
- [Hydrodynamic Analysis of the Flow in an Axial Rotor and Impeller for Large Storage Pump](#)
A I Bosioc, S Muntean, I Draghici *et al.*
- [CFD simulation of degas process in medium consistency pump and experiment](#)
D X Ye, H Li and X D Lai



The Electrochemical Society
Advancing solid state & electrochemical science & technology

242nd ECS Meeting

Oct 9 – 13, 2022 • Atlanta, GA, US

Abstract submission deadline: **April 8, 2022**

Connect. Engage. Champion. Empower. Accelerate.

MOVE SCIENCE FORWARD



Submit your abstract



Design optimization of a centrifugal pump impeller and volute using computational fluid dynamics

J H Kim^{1,2}, K T Oh¹, K B Pyun¹, C K Kim¹, Y S Choi² and J Y Yoon³

¹Department of Mechanical Engineering, Hanyang University, 17 Haengdang-dong Seongdong-gu, Seoul, 133-791, Republic of Korea

²Energy Systems Technology Center, KITECH, 35-3 Hongcheon-ri, Ipjang-myeon, Cheonan, Chungcheongnam-do, 330-825, Republic of Korea

³Department of Mechanical Engineering, Hanyang University 1271 Sa-3-dong Sangnok-gu, Ansan, 425-791, Republic of Korea

E-mail: kjh82@kitech.re.kr

Abstract. In this study, optimization of the impeller and design of volute were carried out in order to improve the performance of a centrifugal pump. Design parameters from vane plane development for impeller design were selected and effect of the design parameters on the performance of the pump was analyzed using CFD and Response Surface Method to optimized impeller. This study also proposed the optimization geometry of pump impeller for performance improvement through the results from numerical analysis that was obtained optimum design pump; efficiency 98.2% and head 64.5m. In addition, the pump design method was suggested by designing volute which was suitable for the optimized impeller through volute design where Stepanoff theory was applied and numerical analysis.

1. Introduction

A pump that has been widely used in industry is the most typical type of fluid machinery that transforms machinery energy into fluid pressure and kinetic energy via impellers. A centrifugal pump, the most common type of pumps, has been used in industrial areas, such as water, sewage, drainage, and the chemical industry. Accordingly, numerous studies have been performed for the designs of various models of centrifugal pumps. Due to the needs of the industry, optimization using mechanical concepts has recently been studied in order to make higher-efficiency pumps with higher heads[1].

An impeller, among all of the components of the pump, has the biggest influence on performance, since fluid flow in the pump generates energy through it. Therefore, an accurate analysis is essential to optimize variables that affect the performance of the pump.

A volute gathers the outflow from the pump and delivers it to the pipe. Due to dynamic pressure loss in the case of generating internal flow, decreased pump performance can occur. In this study, impeller optimization was carried out to satisfy the specifications in Table 1. The meridional plane was fixed to satisfy the conditions of shape constraints. Therefore, it was set under the condition that angle of vane plane development during the procedure. The effects of the design variables were analyzed via numerical analyses, and an optimization model was suggested by response surface methodology. Additionally, the design of the volute was carried out by applying Stepanoff,

and an appropriate design method was suggested through modifying cross-sectional areas of the volute and performance evaluation via numerical analyses.

Table 1. Design specifications of the pump

Design	Specifications
Flow rate	4400 [CMH]
Head	60 [m]
Rotating speed	600 [rpm]
Specific speed	240
Efficiency	85 [%]
Diameter	550 [mm]

2. Methodology for optimization

RSM (Response Surface Methodology) was introduced by Box and Wilson in 1951, and it has been a well-known method for estimating interaction effects among independent variables without implementing factorial design experiments for each level of every independent variable[2]. At least more than two kinds of variables are targets, and an optimization algorithm estimates functional relations between response functions by using the variability of the independent variable. Finally, there are several types of RSMs: two-level factorial designs, when estimations of the response surface are primary, and three-level factorial designs, when estimations of the response surface are secondary. In this study, RSM was carried out based on central composite design.

3. Design optimization of the impeller

3.1. Design of the impeller base model

The shape of the base model was designed to conduct optimization of the impeller. The meridional plane of the base model was designed to satisfy the conditions of shape constraints in the database through previous studies.

The blade inlet angle of the impeller was selected based on the velocity triangle theory, as shown in figure 1, where $V_{n(h,s)}$ expresses the meridional velocity of the hub and shroud; $U_{n(h,s)}$ expresses rotating speed; $V_{n(h,s)}$ expresses relative velocity; and $\alpha_{n(h,s)}$ expresses flow angle.

Meridional velocity ($V_{n(h,s)}$) was defined according to the relationship between flow rate and the cross- section area.

$$V_{n(h,s)} = \frac{Q}{A} \quad (1)$$

The rotating speed of the impeller ($U_{n(h,s)}$) was expressed as the following equations by multiplying angular velocity (ω) by the radius of hub (r_h) or shroud (r_s):

$$\omega = N \times \frac{\pi}{30} \quad (2)$$

$$U_{n(h,s)} = \omega r_{(h,s)} \quad (3)$$

The inlet flow angles ($\alpha_{n(h,s)}$) of the hub and shroud were defined, based on the meridional plane velocity and the rotating speed of the impeller, as follows:

$$\alpha_{n(h,s)} = \tan^{-1} \frac{V_{n(h,s)}}{U_{n(h,s)}} \quad (4)$$

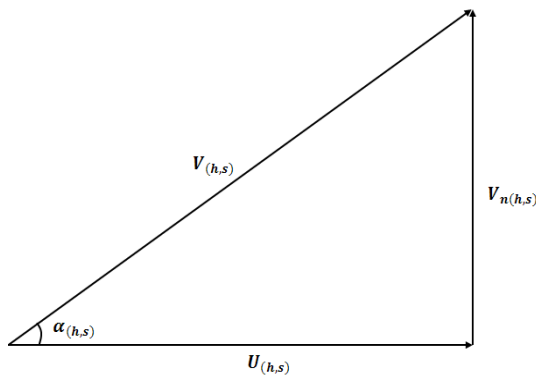

Figure 1. Velocity triangle method



Figure 2. Design of the base model

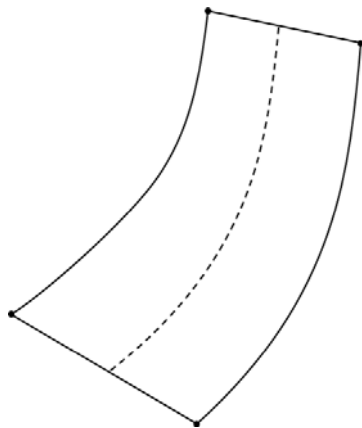

Figure 3. Meridional view of the impeller

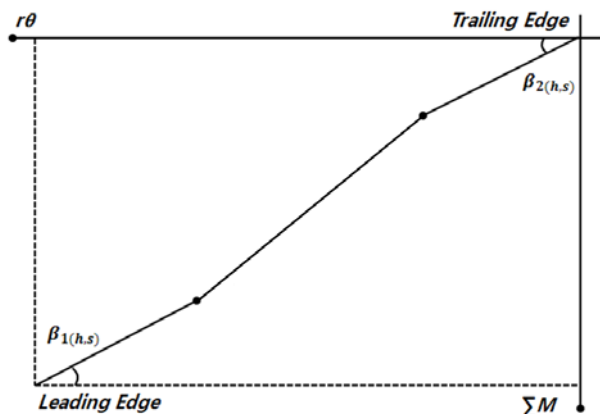

Figure 4. Vane plane development of the impeller

The inlet flow angles of the hub and shroud (37° and 21° , respectively) of the base model were calculated using the velocity triangle theory. The values of the inlet flow angles ($\beta_{I(h,s)}$) were selected as the inlet angle; the incidence angle was 0° . The blade exit angle ($\beta_{2(h,s)}$) of the base model was defined based on a previous study, and the values of the angles were 25° at both the hub and shroud.

Based on the above procedure, the base model design was carried out. The geometry of base model is shown in figure 2.

3.2. Design parameters and sets for numerical analyses

As shown in figure 3, meridional plane data, which expressed the base shapes of blades, and in figure 4, vane plane development data, which expressed the angles and lengths, were required to design the impeller. Thus, considering the design variables of the meridional plane and vane plane development was desirable in the optimization procedure; however, in this study, since the meridional plane had information on the size of the impeller, it could not be modified, due to shape constraints. Therefore, design variables of the meridional plane were not considered.

As shown in figure 4, the inlet and outlet angles ($\beta_{1(h,s)}$, $\beta_{2(h,s)}$) from vane plane development were considered as design variables for optimization. When applied to design variables, incidence angles of the hub and shroud were defined as i_beta_h and i_beta_s by expressing the differences between blade

angles and flow angles. Due to constraint conditions, outlet angles were applied same value for the hub and shroud. This value was defined as beta 2.

Fifteen test sets for performing RSM were generated on the basis of three different variables: i_beta_h , i_beta_s , and beta2. The center model was applied to the previously designed base model.

3.3. Performance evaluation using numerical analyses

Numerical analyses were conducted to evaluate the performance of the test sets of the RSM we calculated. Each test set was changed to a three-dimensional shape using ANSYS BladeGen to perform numerical analyses. Structured grids were generated through ANSYS TurboGrid. Approximately, 90000 grids were generated to one passage. ANSYS CFX v. 12, which was suitable for analysing three-dimensional viscous fluid flow, was used, and the flow in the pump was assumed to be incompressible turbulent flow. In order to analyse the flow region, a three-dimensional Reynolds Averaged Navier-Stokes equation was used, which was discretized via a finite volume method with a high-resolution scheme, for more than second-order accuracy. Meanwhile, a Shear Stress Transport (SST) model, which was suitable for separated flow, was chosen to demonstrate turbulence flow.

Water was applied as a working fluid at 25 °C; atmospheric pressure conditions were applied to the inlet; and mass flow rate conditions were applied to the outlet. In addition, numerical analyses on a passage were conducted periodic interface conditions, by giving the approximate surface between blades.

3.4. Performance evaluation using numerical analyses

The main effect plots regarding the head and efficiency were presented to analyse the effects of the design variables on the pump, based on the results of each test set, as shown in figure 5 and figure 6. From the results, it can be seen that the head of the impeller grew, and was affected by an increase in beta 2 to a greater degree than i_beta_h and i_beta_s . On the contrary, efficiency started to decrease when beta 2 increased above a specific level.

3.5. Optimization of the impeller using RSM

Target specifications was set up to optimize the impeller that the head was 64 m, and efficiency was a maximum value that considered the loss and design margins of the volute for the desired specifications of the pump.

The estimated results of the optimization model that satisfied the objective via RSM is shown in figure 7. The head and efficiency were about 64.6 m and 98.2%, respectively, when both i_beta_h and i_beta_s were -3° and beta 2 was 28°.

Numerical analyses were conducted on an optimization model for accurate performance evaluation; the results, shown in table 2, were compared with the performance of the base model. The results of the numerical analyses show that the head and efficiency were 64.6 m and 98.2%, respectively, and these were approximately equal to the estimated values generated by RSM. Comparing the RSM results with those of the base model, the head increased by about 2.5m, but efficiency decreased by about 0.3%. It was observed that beta 2 increased to satisfy the objective of the head—as has already been shown—so, efficiency decreased very slightly, according to increments of beta 2.

Table 2. Comparison between center and optimized model.

	Head [m]	Efficiency [%]
Base model	62	98.5
Optimized model	64.6	98.2

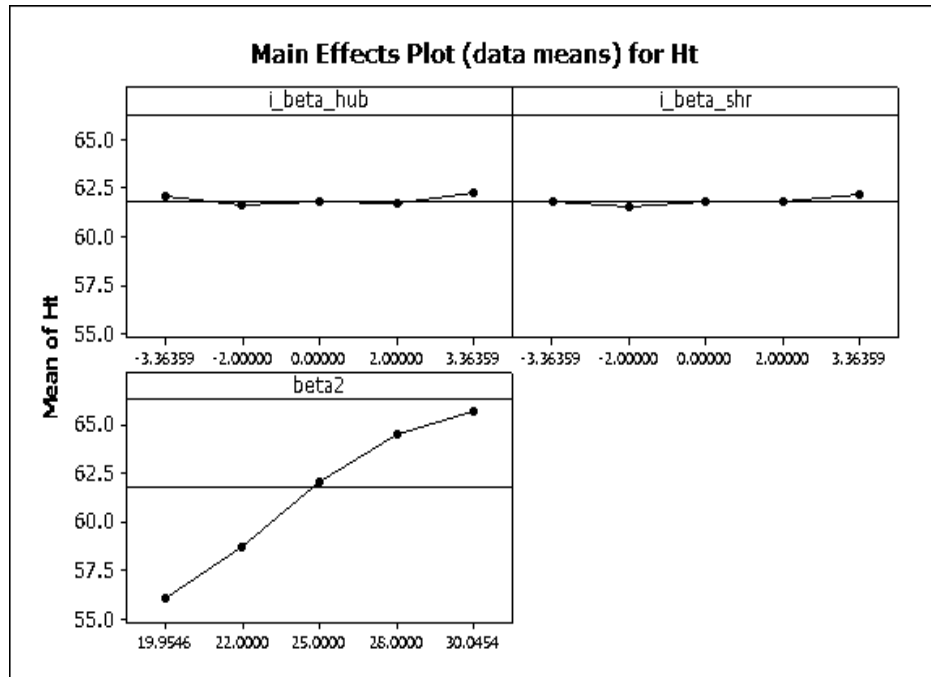

Figure 5. Main effect plot for total head

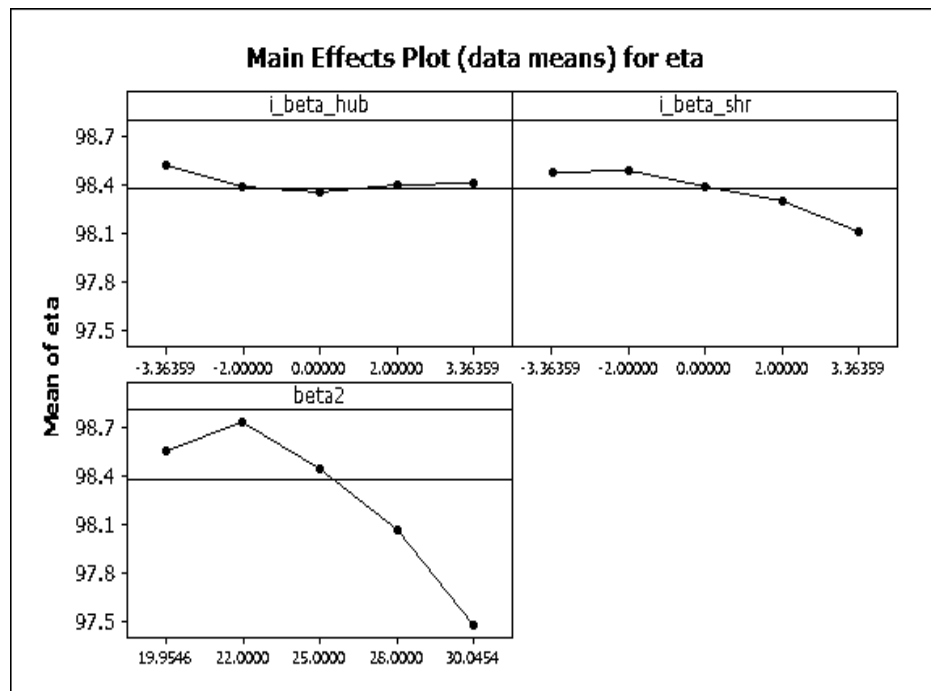

Figure 6. Main effect plot for efficiency

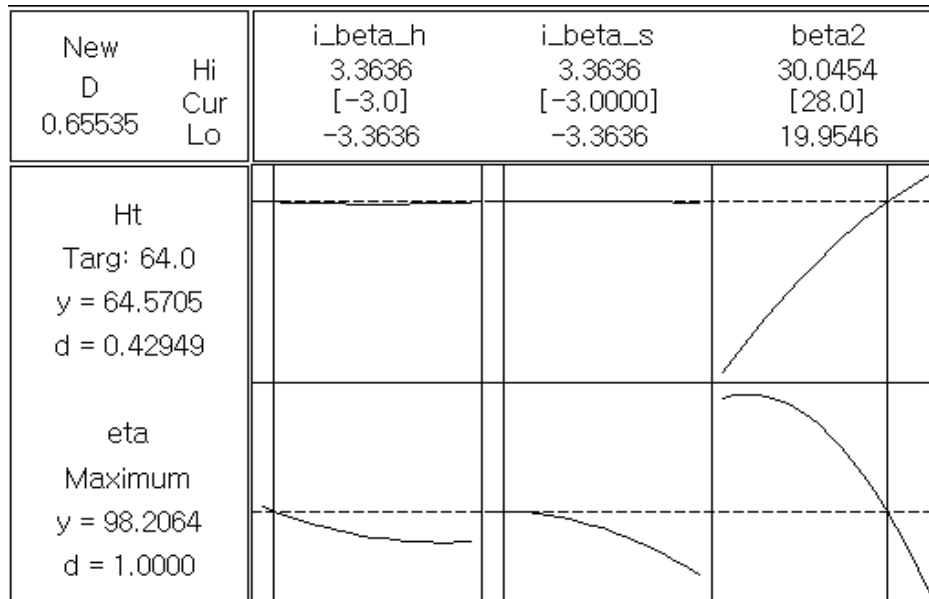

Figure 7. Plot for response optimization

4. Design optimization of the volute

4.1. Design theory of the volute

A volute is a device that gathers outflow and connects to a spiral pipe. Since it has a simple shape, which can be easily manufactured, it has been widely used in centrifugal pumps. When designing the volute, the cross-sectional area from the tongue to the outlet got wider in direct proportionally as shown figure 8[3].

When designing the cross-sectional area of the volute, Stepanoff theory was used. In terms of method, the cross-sectional area was changed along the angle to maintain a constant velocity in the volute[4-5].

Stepanoff theory revised the flow velocity with a constant K, corresponding to the specific speed. The experimental value of K is as follows:

$$K = \frac{2.18}{N_s^{0.32}} \quad (5)$$

The flow velocity in the volute (from Bernoulli's equation), with the constant K, was as follows:

$$V = K\sqrt{2gh} \quad (6)$$

Each cross-sectional area of the volute, while considering velocity from Bernoulli's equation, was as follows:

$$A(\theta) = \frac{Q}{V} \times \frac{\theta}{360} \quad (7)$$

where Q is flow rate of the pump.

In this study, the volute cross-sectional areas were designed via Stepanoff theory. As a result, the velocity in the volute was 13 m/s; each cross-sectional area corresponding to the angle is shown in figure 9.

4.2. Design of the volute base model

Two types of volutes for the optimized impeller model were designed: one had circular cross-section areas, and the other had sector-shaped areas. In the first case, the shape of the internal cross-section area of the volute is as shown in figure 10 and figure 11; the width (b) connected to the outlet of the impeller was fixed to 100 mm; and design variable (R) was controlled for cross-sectional areas corresponding to the Stepanoff theory. In the second case (fan-shaped areas), the width (b) and the divergence angle (θ) were fixed in the same way: 100 mm and 15degree, respectively. Design variables (h1) and (R1) were also controlled, in order to design the model corresponding to the Stepanoff theory. The three-dimensional shape of each designed model of the volute was modelled using Solidworks 2010, shown in figure 12 and figure 13, and mesh generation was done via ANSYS CFX Mesh; more than 3,000,000 unstructured grids was used, and these were concentrated near the wall to maintain a value of y^+ less than 10[6].

Numerical analyses of the optimization impeller model and the volutes were carried out in the same way, in order to evaluate the performance of each model.

The results of performance evaluations through numerical analyses are shown in figure 14 and figure 15. Based on the results, the volute model Type 2 was a suitable design model for the target specifications. Since Type 2 also has an advantage when it is manufactured, it was suggested as a base model for volute optimization.

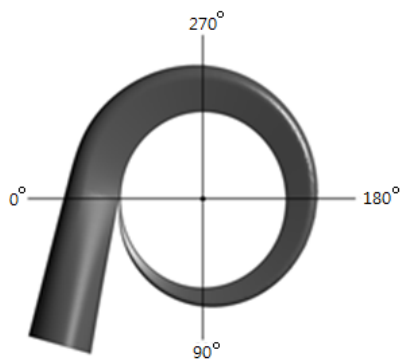

Figure 8. Angle position with volute geometry

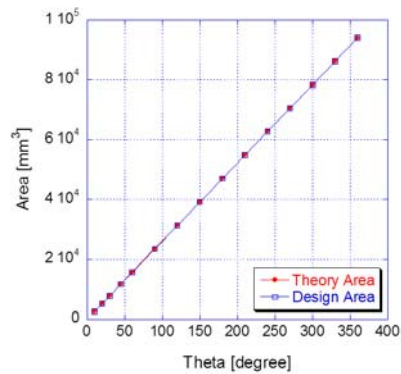

Figure 9. Area distributions of volute models

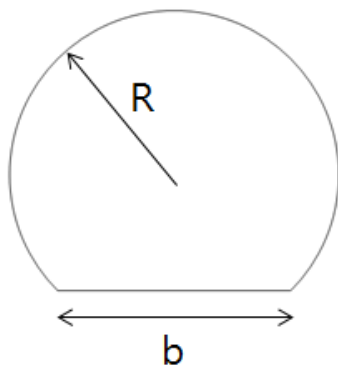

Figure 10. Cross-sectional area concept of volute model type 1

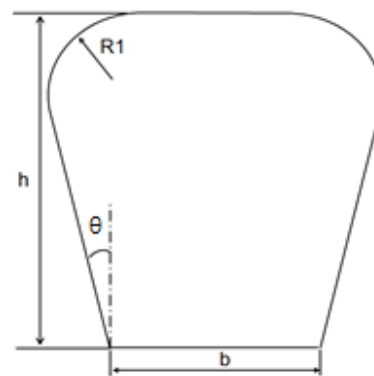

Figure 11. Cross-sectional area concept of volute model type 2

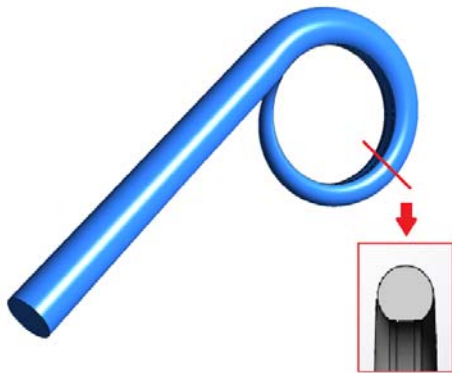

Figure 12. Design of the volute model type1

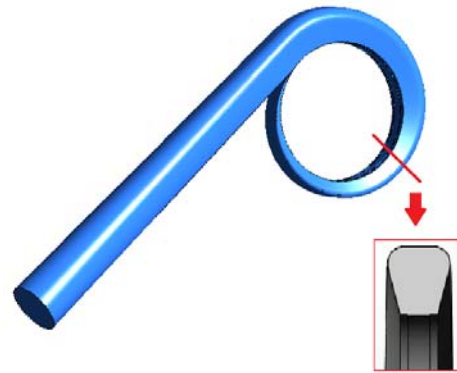

Figure 13. Design of the volute model type2

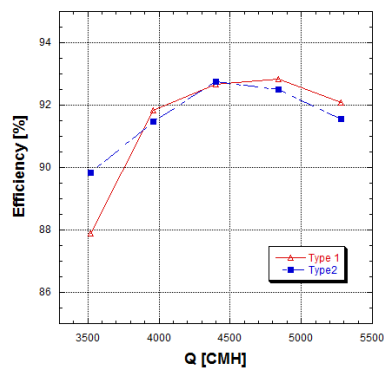

Figure 14. Efficiency curve of volute models

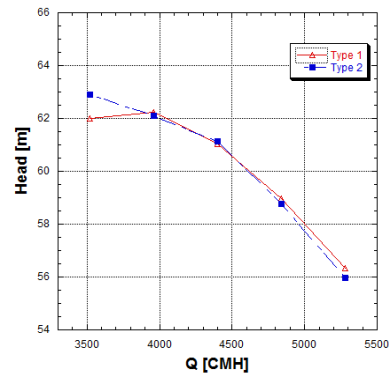

Figure 15. Total head curve of volute models

4.3. Design of the volute optimization model

As has been mentioned, the constant (K) for calculating the velocity in the volute was obtained via experiments, but it could not be concluded that this value was absolutely correct. Therefore, four more volute models were designed, based on Type 2 base models with different cross-sectional area distributions. (Case 1 : 80%, Case 2 : 90%, Center : 100 %, Case 3 : 110%, Case 4 : 120%) Numerical analyses were carried out for each volute model via the same procedure, and the results are shown in figure 16 and figure 17.

Figure 16 shows that the smaller the cross-sectional area was, the higher the head became, at lower flow rate. In addition, the larger the cross-sectional area was, the higher the head became, at higher flow rates. It can be observed that the operation point of the pump was changed by variations in the cross-sectional areas. In case of efficiency, this trend appeared identically according to flow rate variations as shown in figure 17.

As is evident from the results of the performance evaluations of the head and efficiency, according to flow rate, the head was approximately 62 m, and efficiency was about 92.6%. The greatest performance level was observed in the model of the volute designed by the internal cross-sectional area of Case 2 (90%), which was applied at the point of the design flow rate (4400 [CMH]). This performance level met the targeted specifications of the subject centrifugal pump in this study. Based on the results, the volute model of Case 2 was suggested as a design model suitable for the optimization of the impeller.

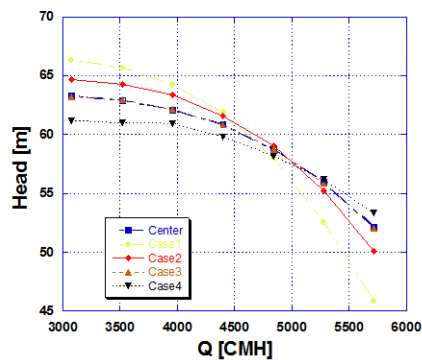

Figure 16. Total head curves of Volute models

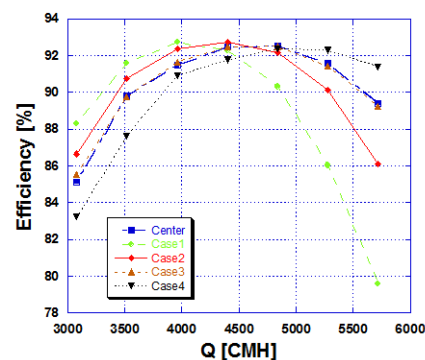

Figure 17. Efficiency curves of Volute models

5. Conclusions

In this study, a design method for a centrifugal pump was suggested to satisfy specifications. To this end, impeller optimization was carried out using CFD and RSM. Finally, a method for designing a volute was suggested via Stepanoff theory.

1) The analyses of the effects of each variable showed that the outlet angle affected the head and efficiency of the impeller the most. As the outlet angle increased, the head increased, while efficiency decreased in cases where the angle increased above a certain level.

2) An optimization model was suggested via RSM. Efficiency decreased slightly to 98.2%, but the head was 64.5 m. It was selected as the optimization model, since it satisfied the objective; namely, that the head should increase by about 2.5 m, and efficiency should decrease by about 0.3%, when comparing the RSM results with those of the base model.

3) Performance evaluations of the pump, performed with each volute model, were conducted via numerical analyses. Case 2–Type 1(90% of the internal cross-sectional area) volutes showed the best performance levels: the head and efficiency were approximately 62 m and 92.6%, respectively. For these reasons, the volute model (90%) is suggested as a design model, which is suitable for the optimization of the impeller model.

References

- [1] Kim S 2007 Design Optimization of a Centrifugal Pump Impeller using DOE and RSM *Master Thesis* (Seoul:Hanyang university)
- [2] Park S H 2001 Modern Design of Experiments, Minyongsa, Seoul 121-140.
- [3] Kim D S, Choi Y S, Jeon S G and Yoon J Y 2006 *J. of Fluid Mach.* **9**(2) 44-49
- [4] Stepanoff A J 1957 *Centrifugal and Axial Flow Pumps* (New York)
- [5] Imaichi K and Murakami Y , Tsurusaki H and Cho K R 2002 *The Basis of Pump Design*
- [6] Kim J H, Choi Y S and Park P J 2009 *J. of Fluid Mach.* 41-42